

Tank and Basin Heaters

Pipe Insert Heaters

Open Coil Pipe Insert Heaters are designed to insert into a horizontal 3" pipe mounted just above the anticipated sludge level in the tank and below the expected minimum operational fluid level. These units provide a low watt density over a large surface area and are used to heat sensitive fluids. Advantages include the ability to change the heater without draining the tank and to provide up to a Schedule 80 pipe wall in mildly corrosive fluids.

Heater pipes can be customer supplied or provided by INDEECO. Pipes can be welded into the tank wall or can be attached with an ANSI flange. INDEECO can also provide a weather-resistant terminal box with NPT threads attached to the end of the heater pipe.

Consult the factory for custom heaters not represented in the following chart.

Catalog Number	Pipe Length (Inches)	KW at 480V 15 W/Sq. In.
797-129915	48	3.95
797-129916	60	5.5
797-129917	72	7.25
797-129918	84	9
797-129919	96	10.5
797-129920	108	12
797-129921	120	14
797-129922	132	16.5
797-129923	144	17.5
797-129924	156	19
797-129925	168	20

Based on a 12" cold length.

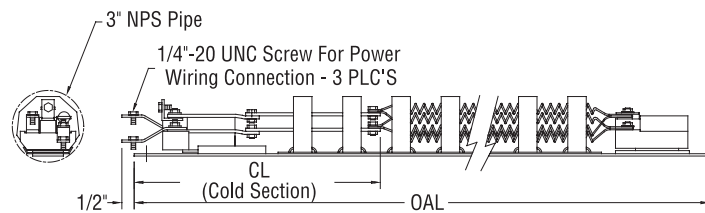

Deep Tank Heaters

Deep Tank Heaters are designed to fit into a manhole of an enclosed tank or double wall tank installed either above or below grade. Often the riser is "split" to facilitate installation. Watt densities can vary from 50 W/Sq. In. for water applications to 5 W/Sq. In. for heavy fuel oils. Controls are often provided to avoid penetrating the tank elsewhere. The element bundle diameter can range from a 12" O.D. to a maximum of 22" O.D.

Steel NEMA 4 Box

12 W/Sq. In.

Number of Elements	KW	Dimensions (Inches) E	Catalog Number	Availability			
				1 Phase		3 Phase	
				480V	208V	240V	480V
3	5	6	747N063	•	•	•	•
6	7.5	9-1/2	747N073	•	•	•	•
9	10	13-1/4	747N083	•	•	•	•
12	15	17	747N093	•	•	•	•
18	20	24-3/4	747N103	•	•	•	•
24	30	32	747N113	•	•	•	•

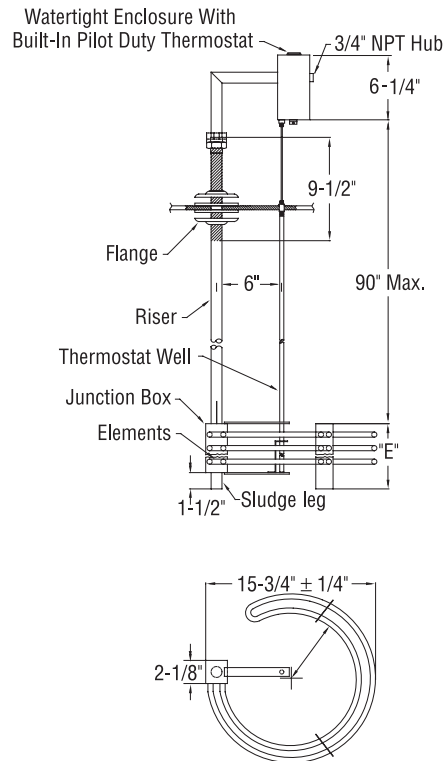

Consult factory for pilot duty thermostat options.

Tank and Basin Heaters

Cooling Tower Heaters

Cooling Tower Heaters are long cartridge heaters designed with a conservative 25 W/Sq. In. maximum watt density. These units provide a long “gentle” heat covering a majority of the tank or vessel. They are used primarily in below grade concrete sumps, for cooling towers or to heat viscous fluids. The heaters can be specified with through-the-wall or over-the-side construction in 3/4” NPT (Series 761) or 1-1/4” NPT (Series 762).

Through-the-Wall Heaters

Series	NPT (Inches)	DIA (Inches)
761	3/4	3/4
762	1-1/4	1-5/16

Over-the-Side Heaters eliminate the need for cutting a hole in the basin. Internal wiring runs from the horizontal heater elements through a vertical riser and extension arm with an outlet box located over the side of the basin.

Adjustable Sludge Legs are furnished on all heaters. Located on five foot centers to keep the element in place even in high water velocities, these legs are adjustable for heights between 2” and 3-1/2”.

Liquidproof/Explosion-Resistant Outlet Boxes are furnished on all heaters.

**Through-the-Wall Cooling Tower Heater
NEMA 4/7 Terminal Box**

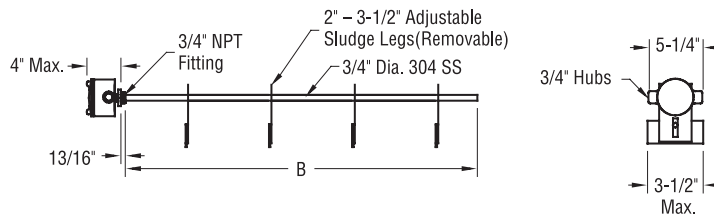

**Over-the-Side Cooling Tower Heater
NEMA 4/7 Terminal Box**

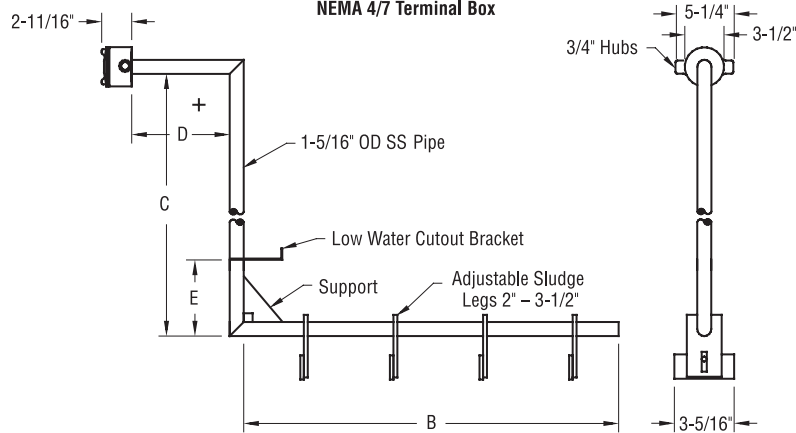

Note: Dimensions B, C, D and E (if required) must be specified when ordering.

Tank and Basin Heaters

Cooling Tower Heaters (continued)

761 Series (3/4" NPT) NEMA 4 Box		
B Dimension (Inches)	Catalog Number	Maximum KW
24	761U024	1.2
30	761U030	1.6
36	761U036	2.0
42	761U042	2.4
48	761U048	2.8
54	761U054	3.2
60	761U060	3.6
66	7617066	4.0
72	761U072	4.4
78	761U078	4.8
84	761U084	5.2
90	761U090	5.6
96	761U096	6.0
102	761U102	6.4
108	761U108	6.8
114	761U114	7.2
120	761U120	7.6
126	761U126	8.0
132	761U132	8.4
138	761U138	8.8
144	761U144	9.2
150	761U150	9.6
156	761U156	10.0
162	761U162	10.4
168	761U168	10.8

762 Series (1-1/4" NPT) NEMA 4 Box		
B Dimension (Inches)	Catalog Number	Maximum KW
24	762U024	2.2
30	762U030	2.8
36	762U036	3.4
42	762U042	4.0
48	762U048	4.6
54	762U054	5.2
60	762U060	5.8
66	762U066	6.4
72	762U072	7.0
78	762U078	7.6
84	762U084	8.3
90	762U090	9.0
96	762U096	9.7
102	762U102	10.5
108	762U108	11.3
114	762U114	12.0
120	762U120	12.7
126	762U126	13.4
132	762U132	14.1
138	762U138	15.0
144	762U144	16.0
150	762U150	17.0
156	762U156	18.0
162	762U162	19.0
168	762U168	20.0